

Project	
Date	
Prepared By	
Model #	AL15050T3BK1

## Specifications

### ELECTRICAL

Watts: 150

Voltage: 100-277VAC

Power Factor:  $\geq 0.9$

THD:  $\leq 20\%$

Operating Temp. Range:  
-40°C (-4°F) to 45°C (113°F)

### LIGHT

Initial Lumens: 19500

Lumens per Watt: 130

Color Temperature: 5000K

CRI:  $>70$

Viewing Angle:

150 x 90 Degree (Type III)

### AGENCY APPROVALS

UL/cUL: Yes

RoHS: Yes

IP65: Yes

### PRODUCT DETAILS

Housing:

Die-cast aluminum alloy

Warranty: 5 years

Fixture

Rated Life: 50,000 hours

Weight: 14.33 LBS

Dimensions:

23.07" Length

13.45" Width

4.3" Depth

# LED Area Light

19500 Lumens, 150 Watt, 5000K, Type III



### ORDER CODE:

11376

### MODEL NUMBER:

AL15050T3BK1

### DLC® PRODUCT ID:

PLAB8NYWWAEG

### REBATE AVAILABILITY\*

## PRODUCT DESCRIPTION

150 watt LED Area Lights provides 19500 lumens for exterior illumination for commercial, industrial and municipal facilities. Constructed from a die-cast aluminum alloy housing and feature an IP65 driver. EarthTronics uses industry-leading LED chips providing an exceptional service life. The area light provides more than 130 lumens per watt and a high 70+ CRI for improved visual acuity and efficient performance. A dusk to dawn sensor is available and is easily added at the time of installation. The design is built to withstand all climates and allows for an extreme temperature range, even operating down to -40 degrees C°, and is IP65 wet location rated. The unique changeable mount system includes the following options: slip fitter with adjustable angle, straight mounts for poles and wall applications and a trunnion (yoke) mount. DLC® Premium listed.

## PRODUCT FEATURES

- + Die-cast aluminum alloy housing provides long life in commercial installations
- + IP65 wet location rated
- + Features 10KV surge protection
- + DLC® Technical Requirement 5.1
- + Bronze powder coat finish
- + Corrosion resistant finish and screws
- + 5 year standard warranty, 10 year project warranty available

## APPLICATIONS

- + Parking Lots
- + Area Lighting
- + Walkways
- + Campuses
- + Grocery Store
- + Commercial

## PRODUCT DIMENSIONS

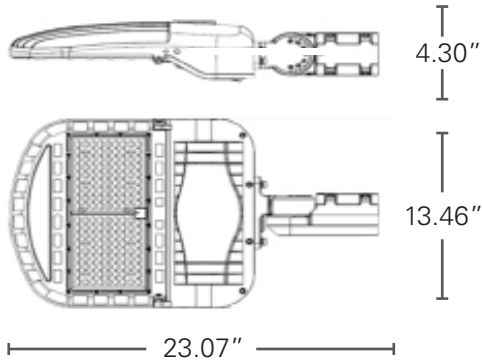

## PACKAGE DETAILS

Dimensions: 25.20" x 15.55" x 7.09"

Weight: 14.55 LBS

UPC: 840791113769

## LIGHT DISTRIBUTION CURVE

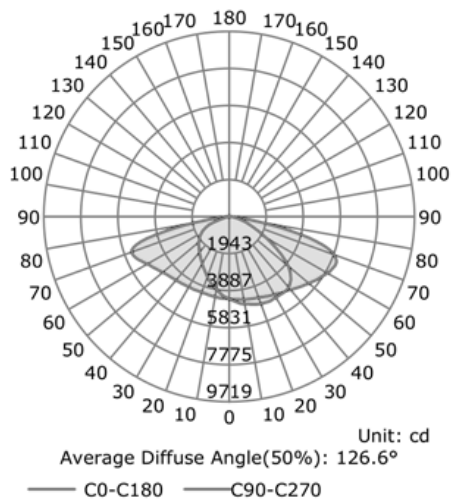

## LIGHTING LAYOUT

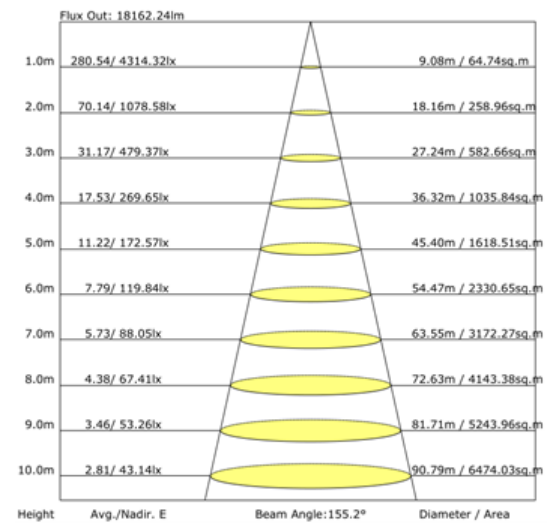

## OPTIONAL ACCESSORIES



Slip-Fitter

Dimensions:  
5.11" x 7.91" x 3.03"  
Order Code: 11383  
Weight: 2.91lbs



Trunnion Mount

Dimensions:  
6.34" x 2.76" x 5.35"  
Order Code: 11381  
Weight: 3.02lbs



Straight Arm  
(Square or Round Poles)

Dimensions:  
5.11" x 10.32" x 6.30"  
Order Code: 11379  
Weight: 4.81lbs



Photocell Kit

Order Code: 11380

Easily access our DLC qualified products with rebates in your area.

ACCESS IT HERE: [Rebate Finder - LED Area Light](#)

[www.earthtronics.com/rebate-finder/catalog/](http://www.earthtronics.com/rebate-finder/catalog/)

